

18-1

Features

- For clamping diameters from 15 mm to 206 mm
- High true running accuracy $\leq 0,01$ mm
- Permissible component tolerance up to IT13
- Extended insertion depth
- Pull-back against external backstop surface or internal backstop ring by the customer
- Hand clamping optional possible
- Impervious to ingress of foreign objects due to the rubberized slots in the Taper Sleeve

Configuration

The Taper Sleeve Flange Chuck consists of a draw plate, a seating body and a Taper Sleeve. A plate with a threaded bore for hand clamping is optionally available. The Taper Sleeve Flange Chuck is attached to the machine with the seating body. The Clamping Fixture is actuated by the draw plate, which is connected to the machine power actuating unit.

Intermediate Flanges and Spring Force Actuators are shown starting on page 58.

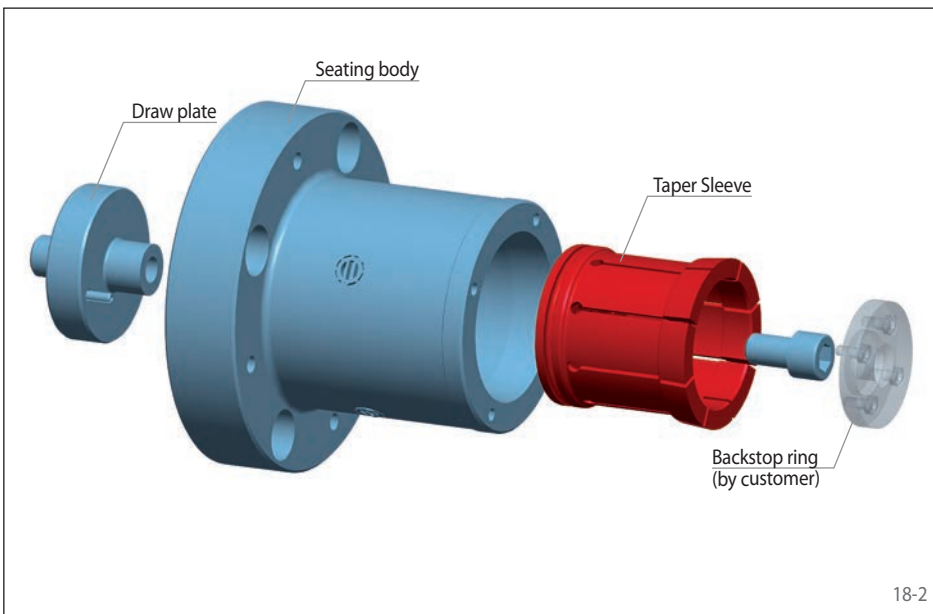

18-2

Clamping principle

For clamping, the Taper Sleeve is pulled against the seating body. The component is centred, pressed against the backstop and aligned flush.

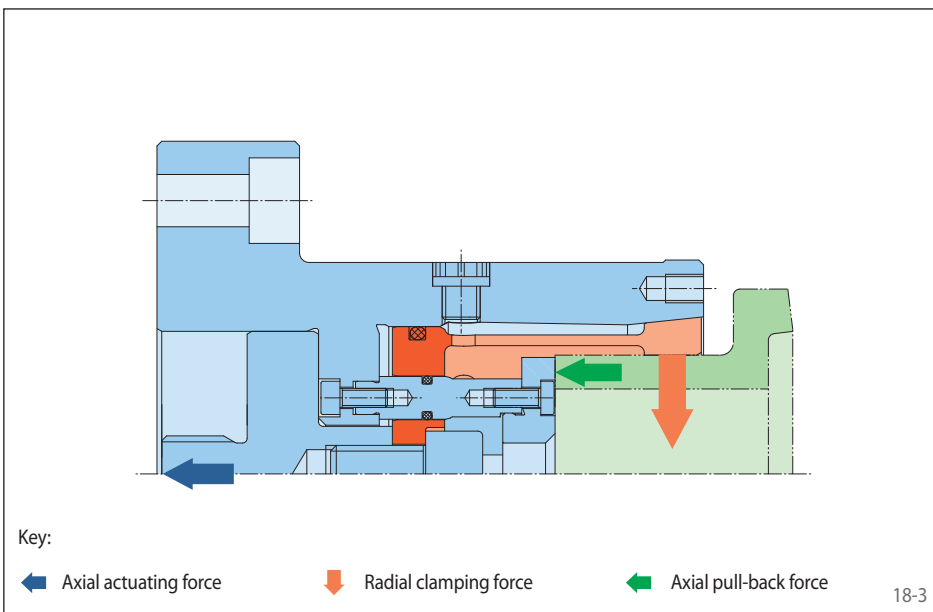

18-3

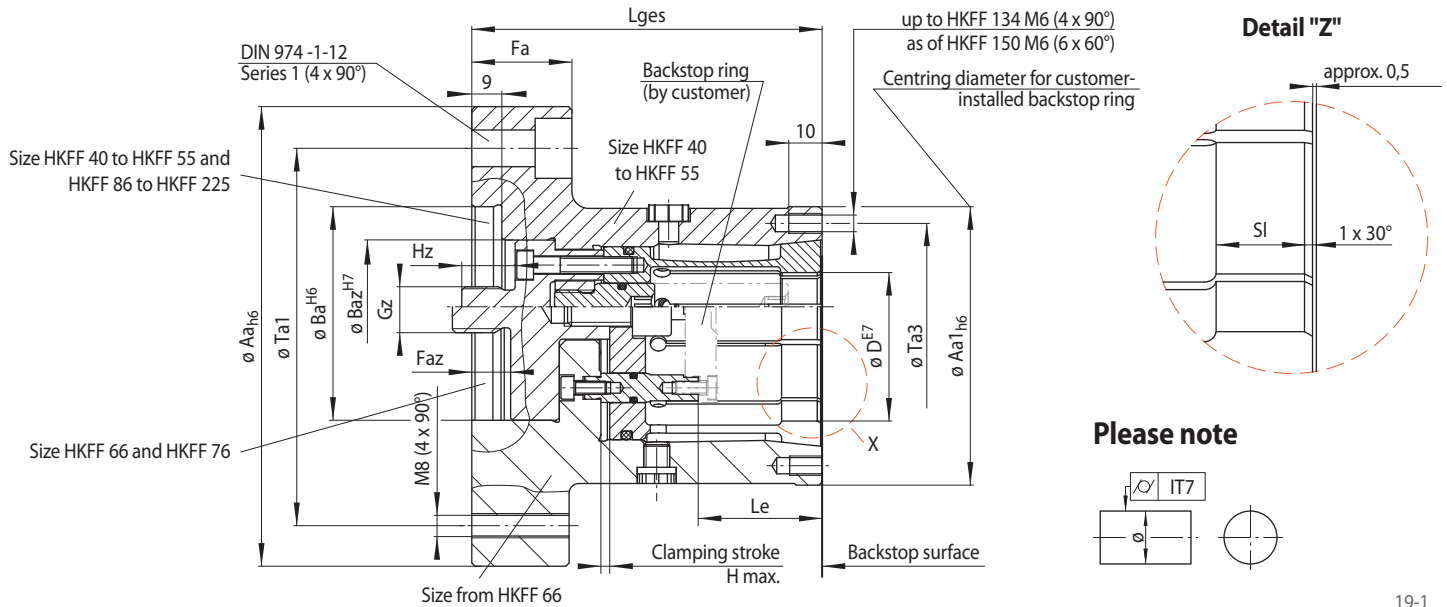

Please note

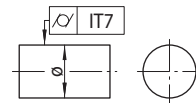

Size	Achievable clamping diameter D* mm	Maximum diameter change** Δ D mm	Max. transmissible torque*** M ¹⁾ Nm	Max. actuating force*** F N	Aa mm	Aa1 mm	Ba mm	Baz mm	Fa mm	Faz mm	Gz	H max. mm	Hz mm	Le mm	Lges mm	SI mm	Ta1 mm	Ta3 mm
HKFF 40	15,00 - 20,50	0,5	20 - 30	10000	120	60	40	40	30	13	M 12	2,7	16	50,2	105	10,5	95	50
HKFF 45	20,00 - 30,50	0,5	50 - 80	17000	120	65	40	40	30	13	M 12	2,7	16	55,2	110	10,5	95	55
HKFF 55	30,00 - 40,50	0,5	90 - 125	20000	120	75	40	40	30	13	M 12	2,7	16	55,2	110	10,5	95	65
HKFF 66	40,00 - 50,50	0,5	130 - 160	20000	140	90	60	-	30	19,0	M 16	2,7	18	38,2	115	11	115	78
HKFF 76	50,00 - 60,50	0,5	160 - 190	20000	140	95	60	-	30	19,0	M 16	2,7	18	38,2	115	11	115	85
HKFF 86	60,00 - 70,50	0,5	240 - 280	25000	160	110	90	70	30	12,0	M 16	2,7	18	38,2	108	11	135	98
HKFF 96	70,00 - 80,50	0,5	280 - 320	25000	160	115	90	70	30	12,0	M 16	2,7	18	38,2	108	11	135	106
HKFF 106	80,00 - 90,50	0,5	390 - 440	30000	185	135	125	84	30	12,0	M 20	2,9	27	39,9	123	13	160	120
HKFF 114	90,00 - 100,50	0,5	440 - 490	30000	185	140	125	84	30	12,0	M 20	2,9	27	39,9	123	13	160	128
HKFF 124	100,00 - 110,50	0,5	570 - 630	35000	200	155	125	105	30	12,0	M 20	2,9	27	39,9	123	13	175	140
HKFF 134	110,00 - 120,50	0,5	630 - 680	35000	225	165	125	105	30	12,0	M 20	2,9	27	39,9	123	13	200	150
HKFF 150	120,00 - 131,00	1,0	685 - 740	35000	225	180	125	80	30	15,5	M 20	6,0	27	57,0	150	14	200	165
HKFF 160	130,00 - 146,00	1,0	740 - 825	35000	250	190	175	80	35	15,5	M 20	6,0	27	62,0	155	14	225	174
HKFF 175	145,00 - 161,00	1,0	820 - 910	35000	250	205	175	80	35	15,5	M 20	6,0	27	72,0	165	14	225	190
HKFF 190	160,00 - 176,00	1,0	905 - 1000	35000	275	225	200	80	40	15,5	M 20	6,0	27	71,0	173	14	250	208
HKFF 205	175,00 - 191,00	1,0	990 - 1080	35000	315	240	240	80	45	15,5	M 20	6,0	27	78,0	180	14	280	222
HKFF 225	190,00 - 206,00	1,0	1075 - 1165	35000	315	260	240	80	45	15,5	M 20	6,0	27	83,0	185	14	280	242

* Clamping diameter adjustable to two places after the decimal point • ** of the clamping diameter of the Clamping Element. • *** for clamping with pull-back action.

¹⁾ The lower value refers to the smallest clamping diameter of the respective size, the higher value to the largest. For values between the two can be determined through interpolation.

Example for ordering

Please indicate the size of the Clamping Fixture and the clamping diameter of your component, including component tolerance, in your order:

Size: HKFF 66
Clamping diameter: 50,47 mm
Component tolerance: h6

➔ HKFF 66-50,47h6