

## Installation and operating instructions for Brake HS 145 FHM

E 09.779e



## **RINGSPANN GmbH**

Schaberweg 30-38  
61348 Bad Homburg  
Germany

Phone +49 6172 275 0  
Fax +49 6172 275 275

[www.ringspann.com](http://www.ringspann.com)  
[info@ringspann.com](mailto:info@ringspann.com)

<b>RINGSPANN</b>	<b>Installation and operating instructions for Brake HS 145 FHM spring activated – hydraulically released</b>	<b>E 09.779e</b>			
Issue: 25.06.2021	Version: 2	Drawn: BAHS	Checked: EISF	Pages: 25	Page: 2

---

## Important

Please read these instructions carefully before installing and operating the product. Your particular attention is drawn to the notes on safety.

These installation and operating instructions are valid on condition that the product meets the selection criteria for its proper use. Selection and design of the product is not the subject of these installation and operating instructions.

Disregarding or misinterpreting these installation and operating instructions invalidates any product liability or guarantee by RINGSPANN; the same applies if the product is taken apart or changed.

These installation and operating instructions should be kept in a safe place and should accompany the product if it is passed on to others -either on its own or as part of a machine- to make it accessible to the user.

---

## Safety Notice

- Installation and operation of this product should only be carried out by skilled personnel.
- Repairs may only be carried out by the manufacturer or accredited RINGSPANN agents.
- If a malfunction is indicated, the product or the machine into which it is installed, should be stopped immediately and either RINGSPANN or an accredited RINGSPANN agent should be informed.
- Switch off the power supply before commencing work on electrical components.
- Rotating machine elements must be protected by the purchaser to prevent accidental contact.
- Supplies abroad are subject to the safety laws prevailing in those countries.

**This is a translation of the German original version!**

In case of inconsistencies between the German and English version of this installation and operating instruction, the German version shall prevail.

<b>RINGSPANN</b>	<b>Installation and operating instructions for Brake HS 145 FHM spring activated – hydraulically released</b>			<b>E 09.779e</b>	
Issue: 25.06.2021	Version: 2	Drawn: BAHS	Checked: EISF	Pages: 25	Page: 3

## Contents

- 1 DESCRIPTION OF THE CALIPER**
  - 1.1 Principle
  - 1.2 Delivery condition
- 2 INSTALLATION**
  - 2.1 Preparing the positioning area
  - 2.2 Installing the disc
  - 2.3 Installing the caliper
  - 2.4 Initial start-up
- 3 OPERATIONAL RUNNING**
  - 3.1 Caliper tightening
  - 3.2 Caliper untightening
  - 3.3 Caliper manual release
- 4 PERIODIC MAINTENANCE**
- 5 MAINTENANCE**
  - 5.1 Manual release: activation
  - 5.2 Manual release: deactivation
  - 5.3 Adjustment of brake pad clearance, pad wear take up
  - 5.4 Replacement of worn brake pads
  - 5.5 Opening and wear contacts (mechanicals) adjustment
- 6 SPARE PARTS**
- 7 TROUBLESHOOTING**

<b>RINGSPANN</b>	<b>Installation and operating instructions for Brake HS 145 FHM spring activated – hydraulically released</b>			<b>E 09.779e</b>	
Issue: 25.06.2021	Version: 2	Drawn: BAHS	Checked: EISF	Pages: 25	Page: 4

## 1 Description of the caliper

### 1.1 Principle

The HS 145 FHM calipers are hydraulic fail-safe calipers; the braking force is applied by spring washers and hydraulic pressure is necessary to hold the brake released. The stack of spring washers is adjusted in factory. This adjustment, combined with adjustment of the pads gap, determines the braking torque value.

There is a type plate on the brake with a 16-digit article number. The exact design of the brake is defined by this article number only.

As well as these instructions, please also consider the catalogue data for the brake at [www.ringspann.com](http://www.ringspann.com) and the drawings in the individual sections.

The caliper is describe as “manually readjusted”. This means that the pad wear must be compensated for by manual adjustment of the pad gap to avoid any loss of braking force.

The brakes have a manual release device mechanically holding the caliper open, without any need for a hydraulic pressure. This release is useful for installation and maintenance work when there is no hydraulic pressure available.

### 1.2 Delivery condition

The caliper is delivered in the following conditions:

- In manual release position, i.e. manually locked in open position,
- With pads installed,
- The holding force adjusted according to customer’s specifications,
- Mechanical contacts adjusted,
- With bleed screw in correct position.
- As well as these instructions, please also consider the catalogue data for the brake at [www.RINGSPANN.de](http://www.RINGSPANN.de) and the drawings in the individual sections.

<b>RINGSPANN</b>	<b>Installation and operating instructions for Brake HS 145 FHM spring activated – hydraulically released</b>			<b>E 09.779e</b>	
Issue: 25.06.2021	Version: 2	Drawn: BAHS	Checked: EISF	Pages: 25	Page: 5



**Life-threatening danger!**

**Disc must be absolutely degreased before all contact with the brakes linings.**

**In case of lining pollution with grease, the nominal brake force is not guaranteed.**

**Calipers are fail safe components.  
All setting and repairs must be performed by skilled operators.**

**BE CAREFUL: The caliper is delivered in " manual release" position and the holding force is adjusted in the factory.  
Instructions in this manual must be followed up to chapter 2.4 inclusive (INITIAL START-UP) to ensure that the brake is operational.**

**When assembling, operating and maintaining the brake it is to be ensured that the entire drive train is secured against being switched on unintentionally. Moving parts can cause severe injury. Rotating parts (e.g. brake disc) must be secured by the operator against unintentional touching.**

**Strongly pre-loaded pressure springs are installed in the springed thrusters of the brake. The spring thruster may only be disassembled by the factory.**

## **2 Installation**

### **2.1 Preparing the positioning area**

Ensure that the positioning surface is clean and dry.  
Make sure that there is sufficient space around the brake.  
Check that the mounting holes are in conformity (center distances, sizes and numbers).

Brake HS 145 FHM-270 L-H (Thrustor mounted left shown)

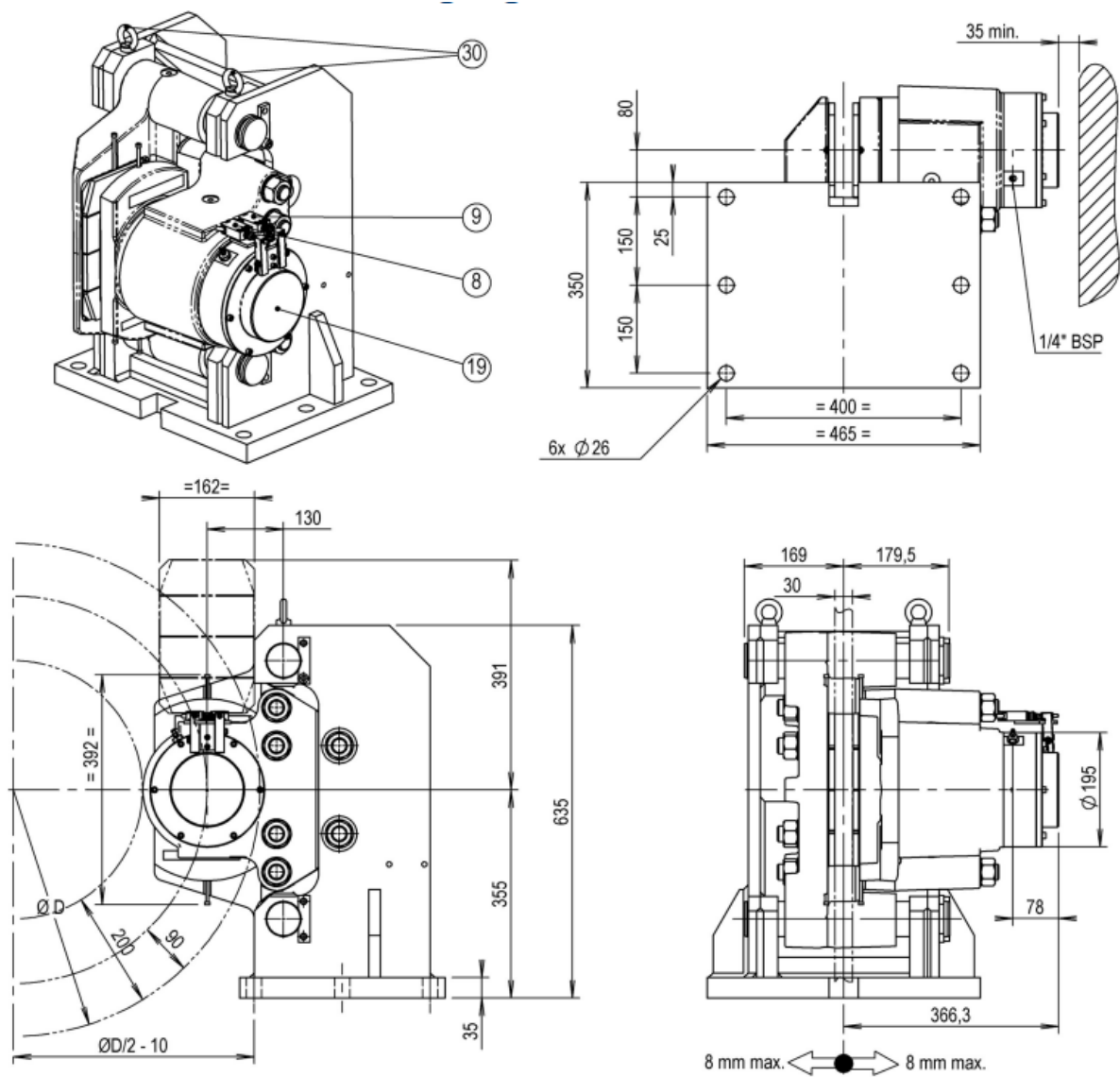

Fig. 2.1

### Brake HS 145 FHM-270 R-V

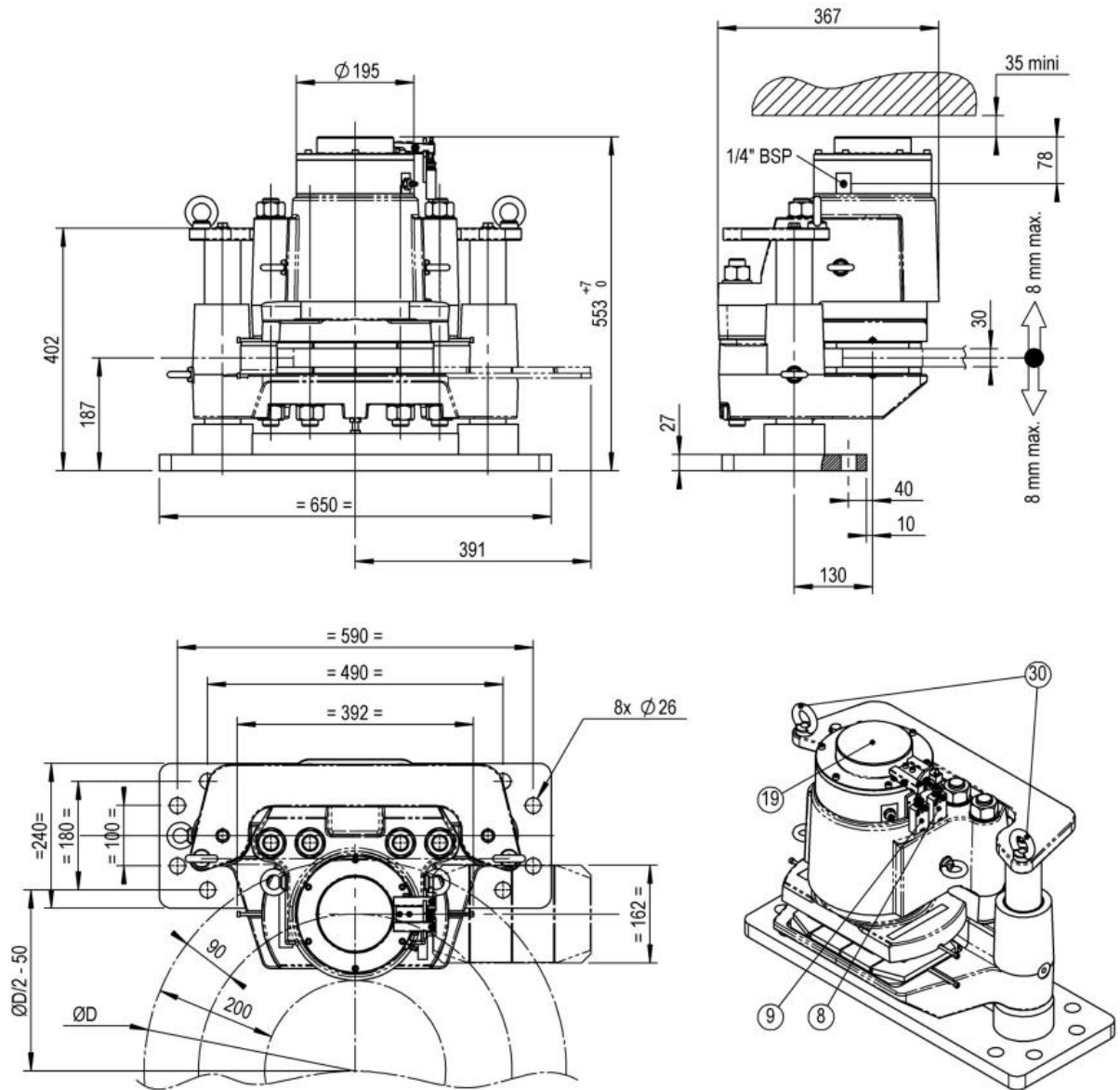

Fig. 2.2

- 8 Brake off monitoring switch
- 9 Pad gap monitoring switch
- 19 Manual release and adjustment screw
- 30 Lifting eyes

#### 2.2 Installing the disc

Make sure that the disc is accurately positioned and attach it to its hub.  
 Check that the disc is not buckled more than 0.3mm.  
 Check that the disc is 30mm thick standard arrangement.

<b>RINGSPANN</b>	<b>Installation and operating instructions for Brake HS 145 FHM spring activated – hydraulically released</b>			<b>E 09.779e</b>	
Issue: 25.06.2021	Version: 2	Drawn: BAHS	Checked: EISF	Pages: 25	Page: 8



**Important!**

**If these conditions are not complied with, the caliper cannot be assembled or will not operate to standard. Contact RINGSPANN for more details.**

First clean the disc tracks with the degreasing agent:

- Quick drying degreaser (CRC / KF)



**Important!**

**BE CAREFUL: The disc must be degreased and free of any deposits so as not to decrease the friction coefficient.**

## 2.3 Installing the caliper

### 2.3.1 List of tools

1. 630Nm torque wrench, socket measuring 36mm across flats (caliper attachment).
2. AF spanner + Flexible pipe inside Ø6mm (Bleed).

### 2.3.2 Brake handling

Put the assembly in position on the disc, raising it with lifting eyes Fig 2.1 and Fig. 2.2.  
Weight for one caliper: HS 145 FHM-\_\_\_ H = 330kg HS 145 FHM-\_\_\_ R-V = 330kg

### 2.3.3 Alignment procedure

1. Brake HS 145 FHM-270 R-V Check the disc position 187 +/-8 mm Fig. 2.2 use the balancing screw (16mm on flats) below the caliper and that the disc is parallel // 0,3 to the brake pad. Check that the support balance in relation to the disc is less than 0,2mm. Check that the disc is fully between the pads. Read before also chapter 5.1.
2. Brake HS 145 FHM-270 H the disc position 8mm min. fixed pad side 2a; 8 mm min. from the other side 2b can be adjust. Fig. 2.3.



<b>RINGSPANN</b>	<b>Installation and operating instructions for Brake HS 145 FHM spring activated – hydraulically released</b>			<b>E 09.779e</b>	
Issue: 25.06.2021	Version: 2	Drawn: BAHS	Checked: EISF	Pages: 25	Page: 9

A crowbar can be used in the area shown by the arrow **2a** and **2b** to slide the caliper from one side to the other.

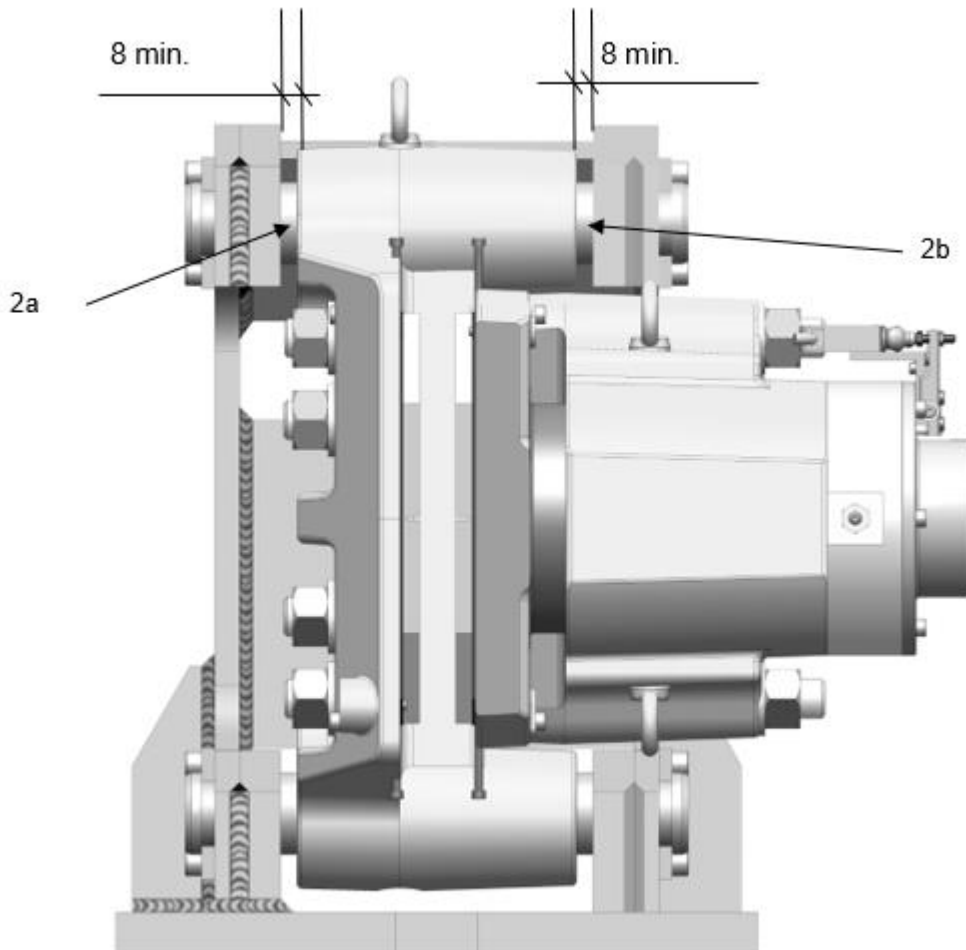

Fig. 2.3

Check that disc deflection in relation to the support does not exceed 0.3mm.  
Check parallelism of the fixed pad **3** Fig. 2.4 in relation to the disc using a set of laminated shims, in compliance with the following spacing:

Transversal spacing: 0.2mm maxi. over pad width.

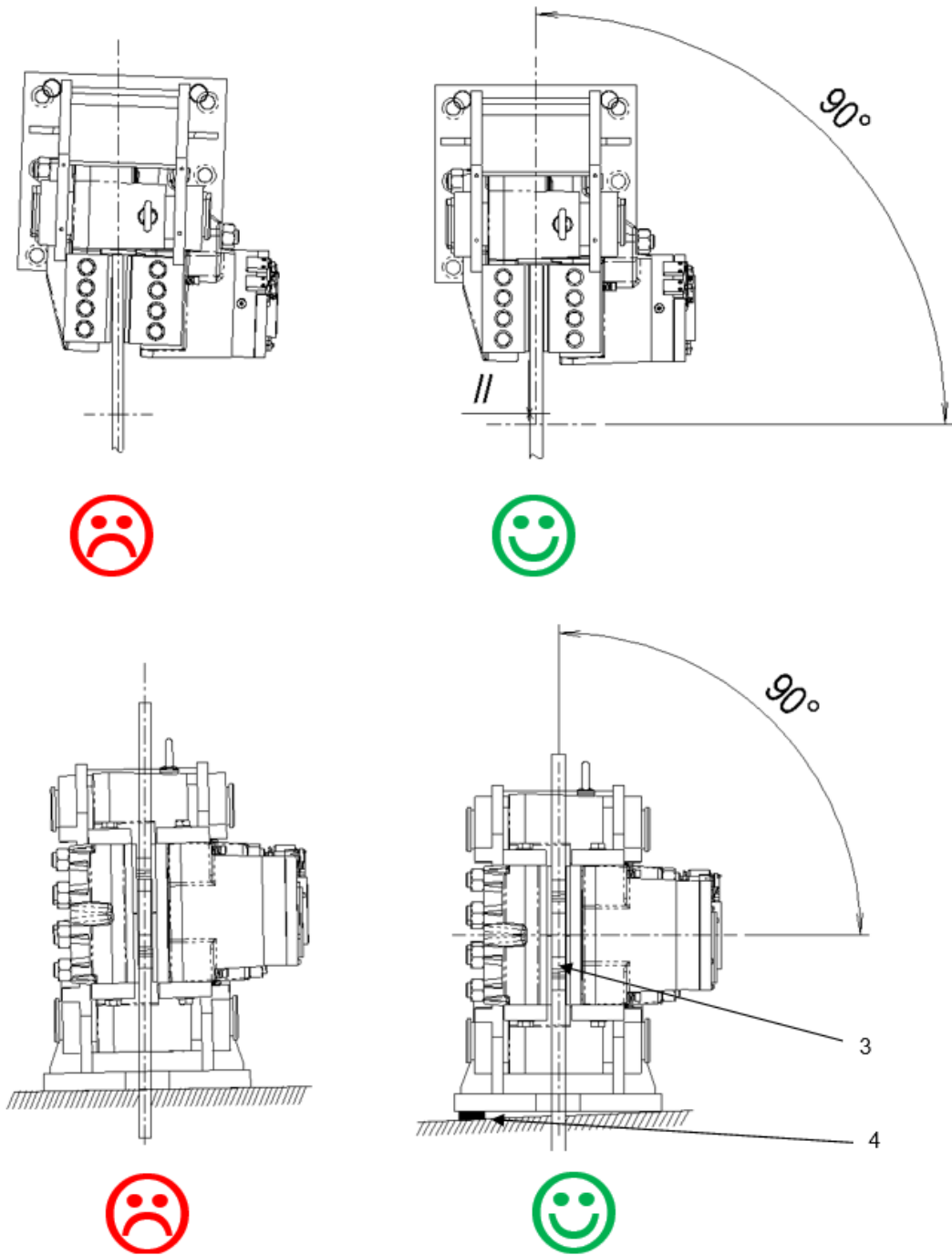

Fig. 2.4

Longitudinal spacing: 0.3mm max. over pad length. If necessary, set the support using foil 4 located close to the attachment screws Fig. 2.4.

<b>RINGSPANN</b>	<b>Installation and operating instructions for Brake HS 145 FHM spring activated – hydraulically released</b>			<b>E 09.779e</b>	
Issue: 25.06.2021	Version: 2	Drawn: BAHS	Checked: EISF	Pages: 25	Page: 11

3. Position the screws M24 class 8.8 for caliper to the basement connection.

The tightening torque (Cs) which has to be applied on the screws M24 class 8.8 rows for each nut is: **Cs = 630Nm ±5% μ=0,15** with greased screws.

Brake HS 145 FHM-270 R-V	8 screws M24 class 8.8
Brake HS 145 FHM-270 L(R)-H	6 screws M24 class 8.8



**Important!**

**Check the tightening torque**

4. Check, after having tightened to torque, that the whole part has not moved.

#### 2.3.4 Orientation of the piston heads

If the caliper stands on a horizontal support, the orientation of the piston heads is not important.

For other positions, the piston heads must be oriented: Bleed screw 11271-17 on top Fig. 2.5 and connecting plug on bottom Fig. 2.5, in a vertical plan ± 30°. For more information, please contact RINGSPANN.

#### 2.3.5 Hydraulic connection



**Important!**

**Opening pressure: 230Bar  
MAX PRESSURE: 250bar**

For an ambient temperature range from 0 through 60°C, recommended oil is ISO HM32. By instance, RINGSPANN uses FUCHS RENOLIN EXTRA 32S.

Use a mineral oil with a viscosity range between 10 and 380mm<sup>2</sup>/s (optimal range between 12 and 100mm<sup>2</sup>/s) while allowing for the ambient temperature conditions



**Important!**

***This oil must be clean  
(maximum permitted level of pollution as per NAS 1638: 10μm).  
Use only new fluid and never mix several types all brands of fluid.***

The caliper must be connected to its source at a hydraulic pressure 250bar max, by threaded plug G 1/4" Fig. 2.5.  
Do not use hemp, mastic, Teflon (etc.) and use flexible hoses exclusively.  
It is preferable to use liquid joints.  
Clean the pipes and couplings while ensuring that they are perfectly clean (soiling, scale, swarf, etc.).

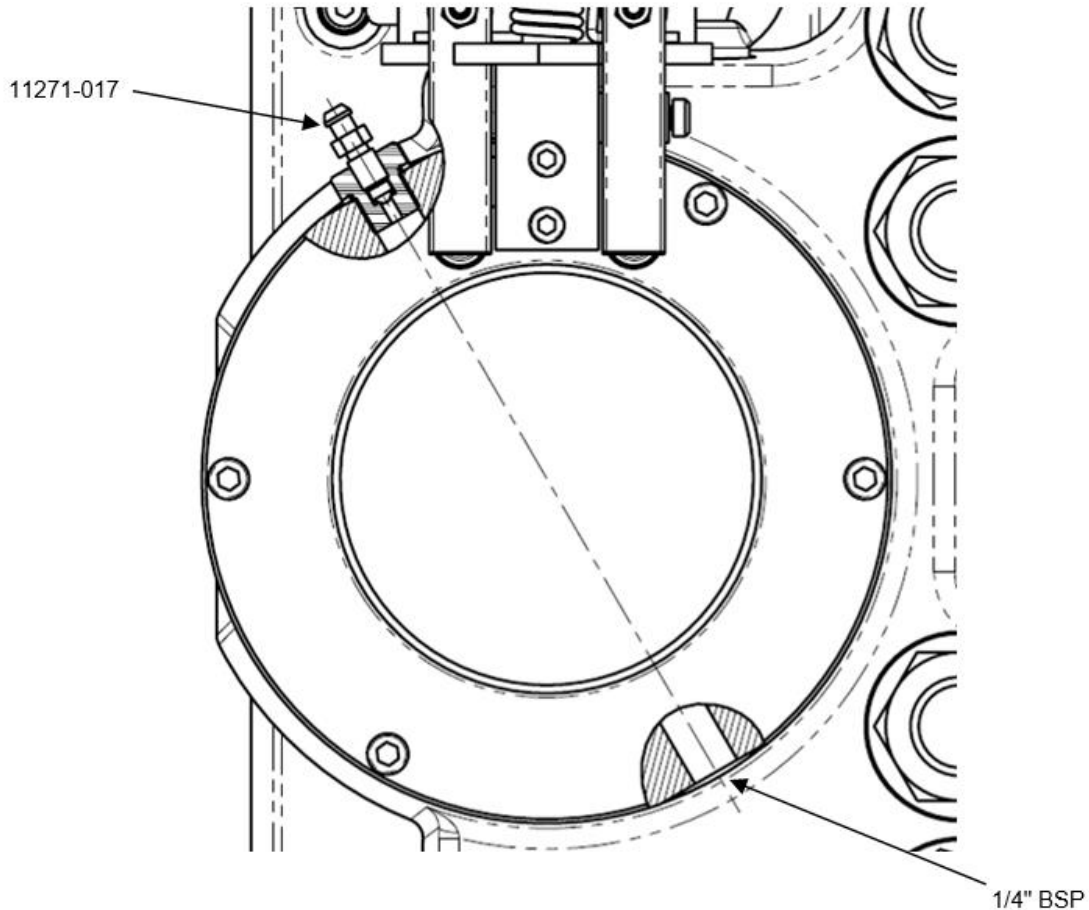

Fig. 2.5

### 2.3.6 Electrical connection

Opening and wear contact:

Bipolar switch  
Mechanical contact output by  
cable 5 wire x 0.75mm<sup>2</sup>  
Standard length of the cable: 2m.

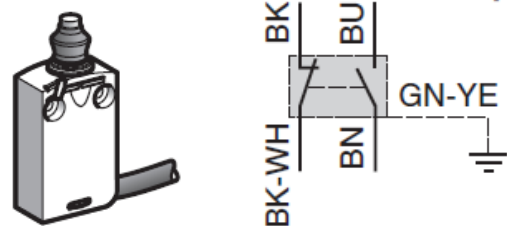

Fig. 2.6

<b>RINGSPANN</b>	<b>Installation and operating instructions for Brake HS 145 FHM spring activated – hydraulically released</b>			<b>E 09.779e</b>	
Issue: 25.06.2021	Version: 2	Drawn: BAHS	Checked: EISF	Pages: 25	Page: 13

## 2.4 Initial start-up

### 2.4.1 Hydraulic circuit bleed

Tools: Spanner, 6mm ID flexible hose.



#### **Important!**

**Take the necessary precautions to avoid the oil being sprayed onto the disc.**

1. Connect the bleed screw 11271-17 to a 6mm ID flexible hose and put the end of the hose into a container Fig. 2.7.
2. Feed oil to the caliper from the power pack, then from the hand pump.
3. Loosen slightly the bleed screw 11271-17.
4. When the oil pours out continuously and there are no more air bubbles at the end of the hose, tighten the bleed screw 11271-17.
5. Disconnect the flexible hose (beware of any oil remaining in the hose)



#### **Important!**

**This file must be clean  
(maximum permitted level of pollution as per NAS 1638: 10µm).  
Use only new fluid and never mix several types all brands of fluid.**

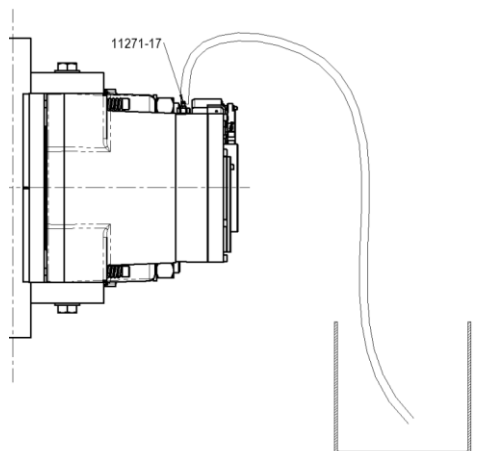



Fig. 2.7

<b>RINGSPANN</b>	<b>Installation and operating instructions for Brake HS 145 FHM spring activated – hydraulically released</b>			<b>E 09.779e</b>	
Issue: 25.06.2021	Version: 2	Drawn: BAHS	Checked: EISF	Pages: 25	Page: 14

#### 2.4.2 Deactivate the manual release

The calipers are delivered full back (excluding hydraulic cylinder run) thanks to manual loosening it is important to deactivate the manual release function see chapter 5.

Refer to chapter 5 for more information about the manual release mode

	<p><b>Important!</b></p> <p><b>The manual release must be deactivated to ensure a well running of the brake.</b></p>
---	--

#### 2.4.3 Adjustments of pad gap

	<p><b>Important!</b></p> <p><b>Check that the electrical switches are operating properly.</b></p> <p><b>It is necessary, follow the procedure chapter 5</b></p>
--	---

First check the thickness of the disc. Use a set of laminated shims to verify that total gap between the pads and the disc corresponds to the "PG= Pad Gap on the type plate.

The pad gap must be equal both side  $PG = (a+b)$

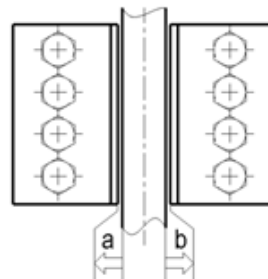



Fig.2.8

	<p><b>Important!</b></p> <p><b>Be Careful: The disc must be degreased and free from any deposits so as not to decrease the friction coefficient.</b></p>
---	--

Check the well running of the electric contacts.

Run the brake under no-load with the disc turning, 20 or so times, to bed in the pads.

<b>RINGSPANN</b>	<b>Installation and operating instructions for Brake HS 145 FHM spring activated – hydraulically released</b>			<b>E 09.779e</b>	
Issue: 25.06.2021	Version: 2	Drawn: BAHS	Checked: EISF	Pages: 25	Page: 15



**Information!**

**THE SYSTEM IS NOW OPERATIONAL**

### 3 Operational RUNNING

#### 3.1 Caliper tightening

The lack of hydraulic pressure allows the pads to be tightened on the disc.  
The opening contact is not activated.

#### 3.2 Caliper untightening

Apply opening pressure to release the brake.  
The opening contact is activated.

#### 3.3 Caliper manual release

Manual release keeps the caliper open without hydraulic pressure.  
Refer to chapter 5.1 and chapter 5.2.

### 4 PERIODIC MAINTENANCE

Every two months, check:

- As a general rule, inspect the entire system for correct operation
- Check that there is not any leakage
- Also, check the brake pad gap see chapter 5.3.



**Attention!**

**When the remaining lining thickness reaches 3mm, proceed to pad exchange as per chapter 5.4. If this rule is not observed, a loss of breaking force may occur.**

Every two years, replace:

- Oil in the *power pack* (refer to the power pack instructions)

Every five years:

- Plan complete overhaul of the entire unit (replace worn parts, seals, spring washers, flexible hoses...)

<b>RINGSPANN</b>	<b>Installation and operating instructions for Brake HS 145 FHM spring activated – hydraulically released</b>			<b>E 09.779e</b>	
Issue: 25.06.2021	Version: 2	Drawn: BAHS	Checked: EISF	Pages: 25	Page: 16

## 5 Maintenance

### 5.1 Manual release: activation

Tools: A/F wrench, Electrician's flat screwdriver.

1. Supply the caliper with opening pressure and maintain the pressure throughout the operation.
2. For an easier handling, it is possible to remove the connector of indicator switches Fig.5.1. Unlock the connector by inserting the screwdriver behind the connector and turn it a 1/4 of a turn counter-clockwise and then insert the screwdriver into the slot at the side to release the connector.

**In 'ATEX' execution, it is not possible to remove the connector**

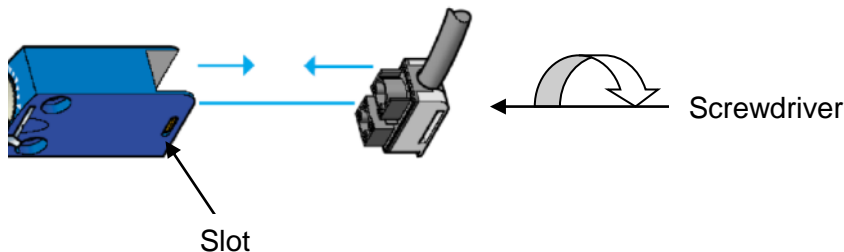

Fig. 5.1

**Note:** Do not remove the detector assembly as this will cause the factory setting to be lost.

3. Remove lid **09** using its 6 screws **V09** with a A/F wrench Fig. 5.2.
4. Remove the locking washer **07** Fig. 5.2 after releasing the screws.
5. Place the pad on the fixed side against the disc, using a crowbar if necessary.
6. Turn axis **10** with a A/F wrench clockwise to move the jaw up to the clearance indicated on the datasheet GP air gap Fig. 2.8.
7. Reinstall the washer **07** and the lid **09** and tighten the screws torque 16 Nm.
8. Push the connectors back into the switches and lock them by turning a flat screwdriver clockwise 1/4 turn.
9. Disconnect the pressure.





**Attention!**

**MOVEMENT IS STILL POSSIBLE AFTER CUTTING OFF THE PRESSURE.**



**Attention!**

Be careful not to reverse the assignment of the connectors on the two switches.

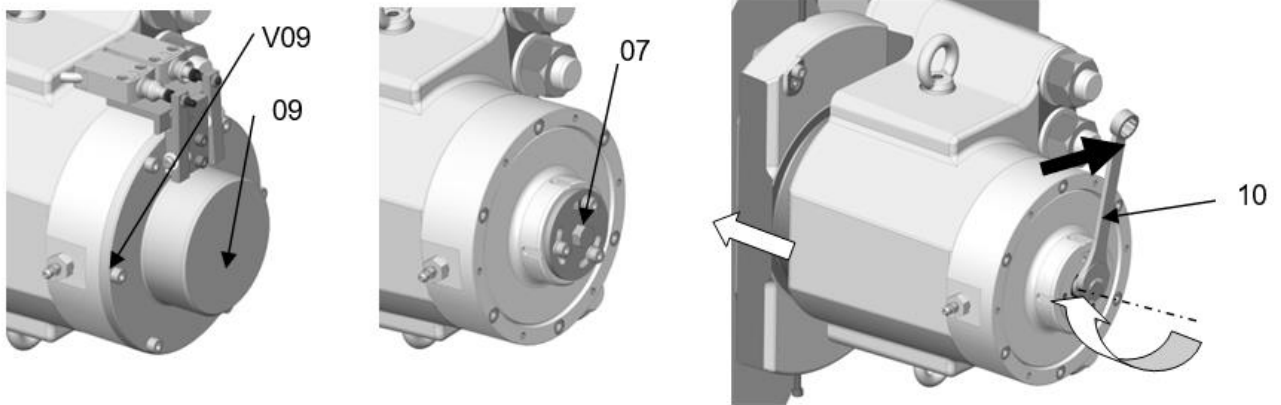

Fig. 5.2

## 5.2 Manual release: deactivation

Tools: A/F wrench, hexagon socket wrench, Electrician's flat screwdriver.

Procedure: The same procedure as in chapter 5.1 Manual release: Deactivation.  
From point 1 to point 9, only at point 6, turn axis 10 against counter clockwise with a spanner to reach manual ventilation.



**Attention!**

Be careful not to reverse the assignment of the connectors on the two switches.

<b>RINGSPANN</b>	<b>Installation and operating instructions for Brake HS 145 FHM spring activated – hydraulically released</b>			<b>E 09.779e</b>	
Issue: 25.06.2021	Version: 2	Drawn: BAHS	Checked: EISF	Pages: 25	Page: 18

### 5.3 Adjustment of brake pad clearance, pad wear take up

Regularly monitor the clearance between the pads and the disc. 1mm increase in this clearance results in a torque loss of 7%. Refer to the datasheet for the nominal clearance PG .

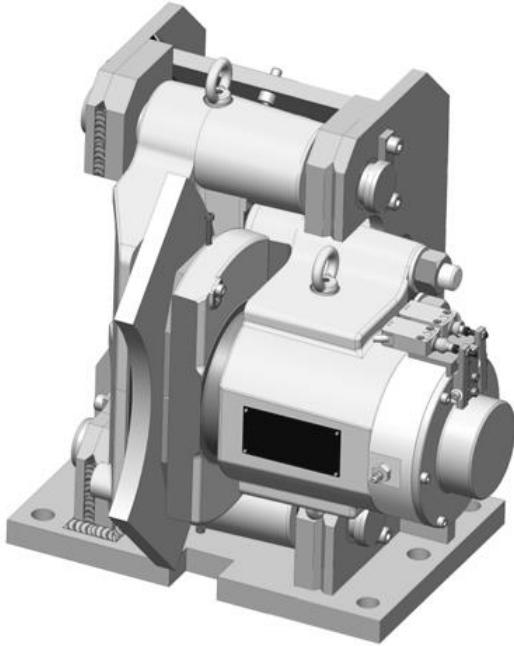

Fig. 5.3



**Attention!**

Regularly monitor the clearance between the pads and the disc. (1mm increase in this clearance results in a torque loss of 7%). Refer to the datasheet for the nominal clearance.



**Attention!**

When the remaining lining thickness reaches 3mm, proceed to pad exchange as per chapter 5. If this rule is not observed, a loss of braking force may occur.

**Only original RINGSPANN brake pads may be used.**

<b>RINGSPANN</b>	<b>Installation and operating instructions for Brake HS 145 FHM spring activated – hydraulically released</b>			<b>E 09.779e</b>	
Issue: 25.06.2021	Version: 2	Drawn: BAHS	Checked: EISF	Pages: 25	Page: 19

Tools: 15 mm A/F wrench - 5 mm A/F 6-sided wrench - Electrician's flat screwdriver.

Procedure: Carry out the same procedure as for the initial adjustment in chapter 5.1 from point 1 to point 9



**Attention!**

Be careful not to reverse the assignment of the connectors on the two switches.

#### 5.4 Replacement of worn brake pads

Tools: AF wrench, hexagon socket wrench, flat screwdriver

Procedure: for mobile pad side

1. Supply the caliper with opening pressure and maintain this pressure throughout the operation.
2. Carry out the same removal procedure as in chapter 5.2 from point 1 to point 6 inclusive.
3. Turn axis **10** with the wrench anti counter clockwise to push back the pad to the maximum Fig.5.4. The clearance between the pad holder and the disc must not be more than: 9 mm + remaining pad thickness.
4. Change now the pad on the fixed side before reinstalling the pad on the thruster side.
5. Insert the Chc M5x70 screws onto the sides of the pad, used as handles, and take pad **11** out of the housing in body **01**.
6. Replace with a new one.
7. Remove the Chc M5x70 screws from the pad.

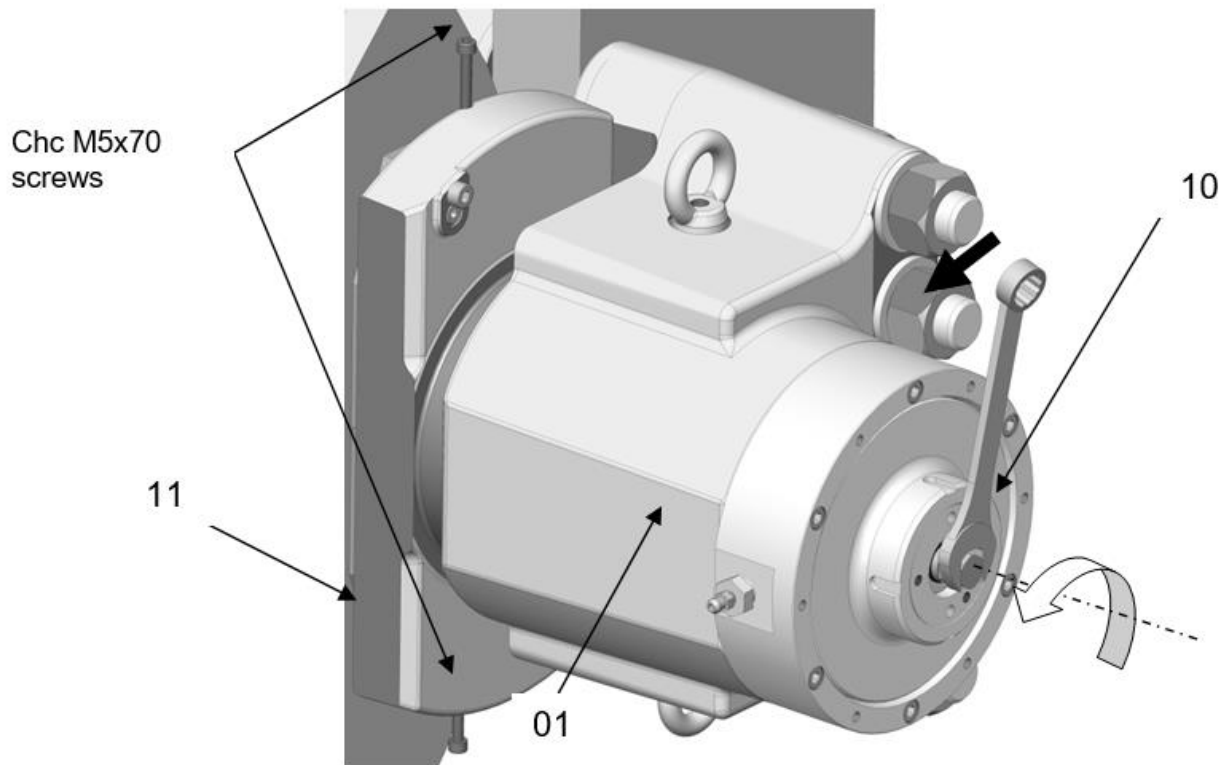

Fig. 5.4

Procedure: For fixed pad side

1. Move the fixed pad holder as far away as possible from the disc **15**, using a crowbar if necessary.
2. Screw 2 Chc M5x70 screws into the side of the pad.
3. Take the pad **11** out of its housing.
4. Replace this pad with a new one.
5. Remove the Chc M5x70 screws.
6. Bring the pad holder closer towards the disc, either to distribute the clearance before adjustment or to facilitate installing the pad on the mobile side.
7. After the pads replacement both side, proceed with the adjustment of the pad gap chapter 5.1 to make the brake operational for uses.

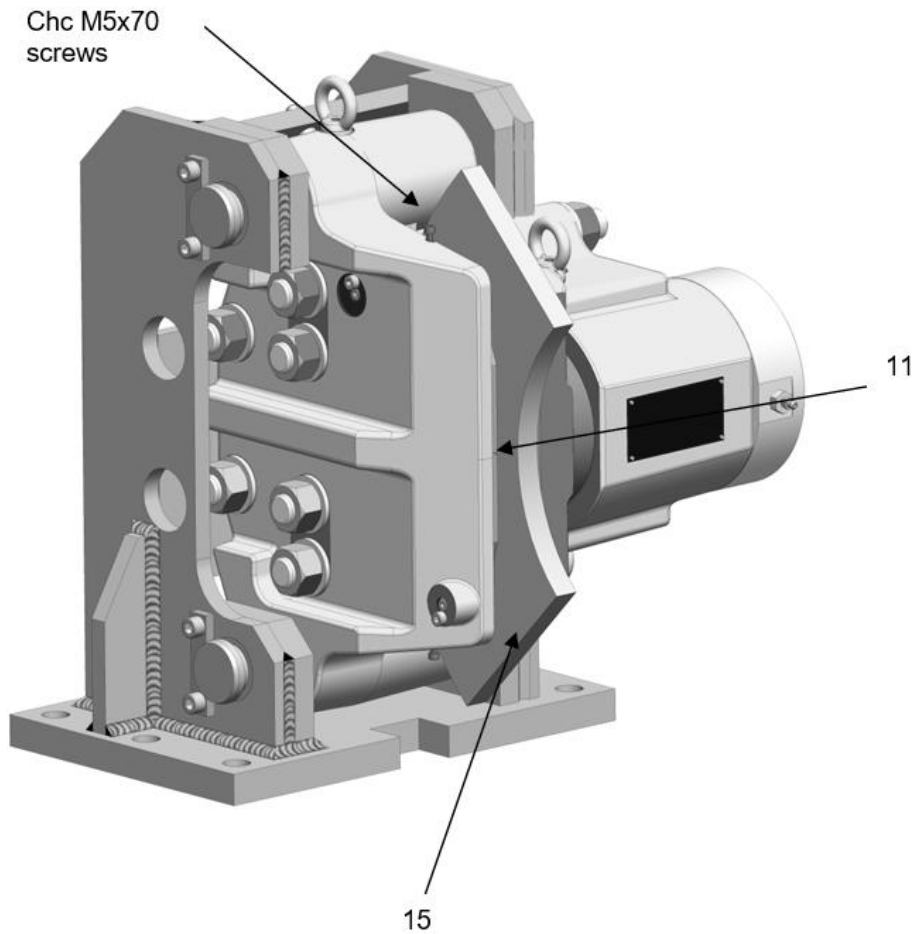

Fig. 5.5

### 5.5 Opening and wear contacts (mechanicals) adjustment



**Information!**

**Contacts are factory set and do not need any adjustment.  
If necessary, follow this procedure.**

Verify the gap for the pad at each caliper, otherwise perform all the operations in chapter 5.2. Refer to the datasheet for the nominal clearance "PG" Pad Gap.

Tools: Allen wrench, AF spanner.

<b>RINGSPANN</b>	<b>Installation and operating instructions for Brake HS 145 FHM spring activated – hydraulically released</b>			<b>E 09.779e</b>	
Issue: 25.06.2021	Version: 2	Drawn: BAHS	Checked: EISF	Pages: 25	Page: 22

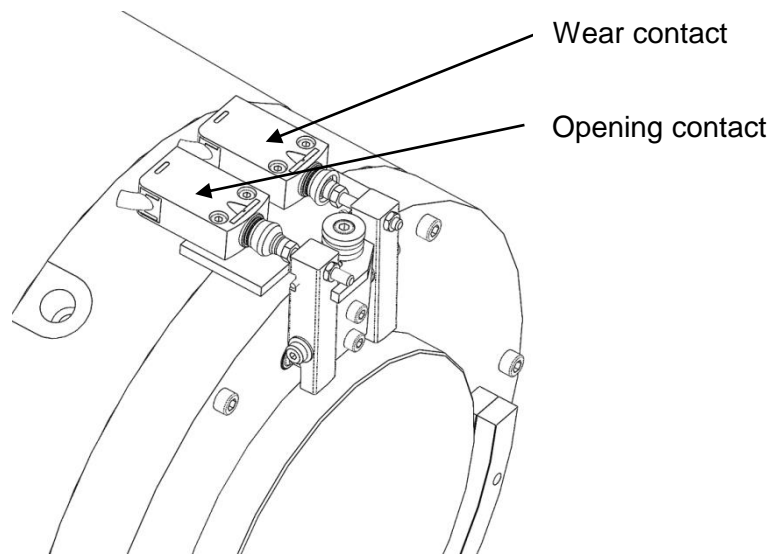

Fig. 5.6

#### 5.5.1 Adjustment of 'brake released' switch

This switch monitors the status of the brake (closed or released)  
It closes when the brake is released (set under pressure).

- Power the brake with opening pressure.
- Unscrew nut **V11** AF spanner.
- Check that the axle **22** is in contact onto lever **41**.
- Adjust the screw **V02** with Allen wrench until the activation of contact. Check that state contact is "Open".
- Cut off pressure. When the brake is close, check the contact state (Position "closed"). If this information is not obtained, unscrew the screw **V02** until change of state.
- Power the brake with opening pressure.
- Check that state contact is "Open". Execute this operation till correct monitoring of the " open & closed" status.
- After an adjustment is finished, do not forget to retighten nut **V11** with AF spanner.

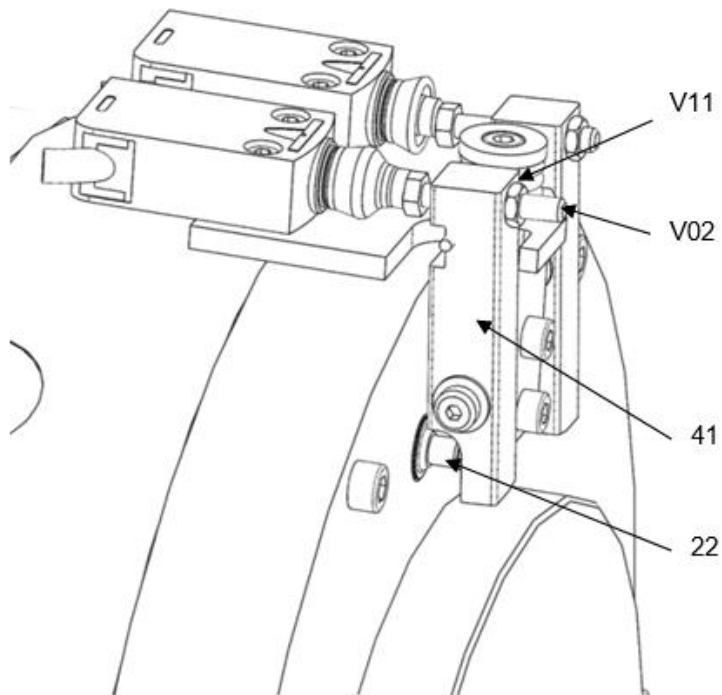

Fig. 5.7

<b>RINGSPANN</b>	<b>Installation and operating instructions for Brake HS 145 FHM spring activated – hydraulically released</b>			<b>E 09.779e</b>	
Issue: 25.06.2021	Version: 2	Drawn: BAHS	Checked: EISF	Pages: 25	Page: 24

#### 5.4.2 Adjustment of 'pad wear' switch

This switch is permanently closed and opens when the pad wear reaches 1mm.

- Power the brake with opening pressure.
- Check that the pads clearance is correctly adjusted, otherwise proceed to adjustment.
- Brake being open, check that the connection pin **22** is in contact onto lever **42**.
- Cut off pressure to close the brake.
- Unscrew nut **V11** with AF spanner then adjust screw **V02** Allen wrench to free it from the switch end adjust the screw skimming the lever.
- Adjust the screw **V02** until the switch triggers (status « worn pads »). When the pads will reach a 1mm wear, the switch will release as the hysteresis of the switch is 1mm.
- After an adjustment is finished, do not forget to retighten nut **V11** with AF spanner on the screw **V02**.

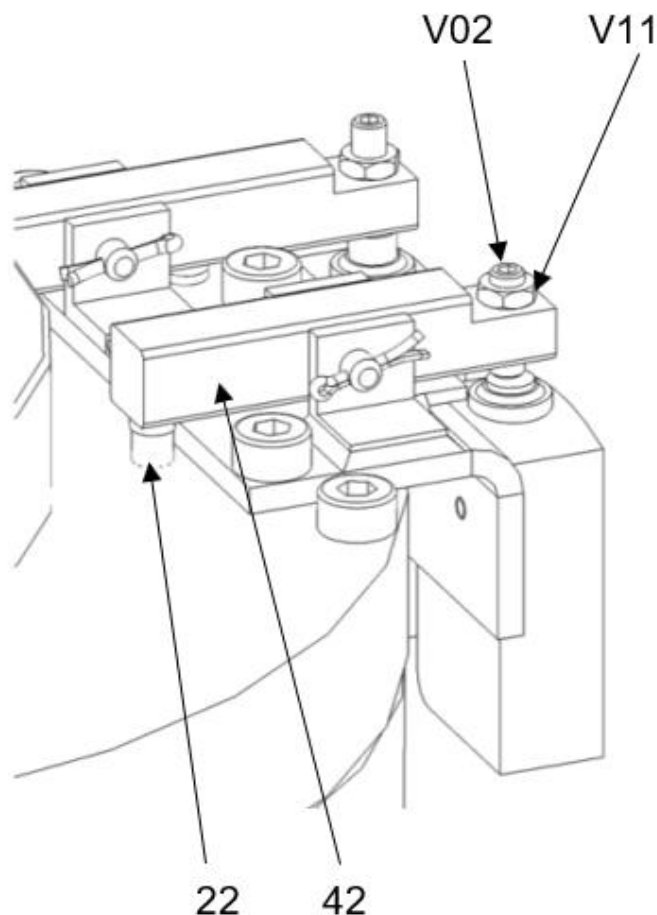

Fig. 5.8



<b>RINGSPANN</b>	<b>Installation and operating instructions for Brake HS 145 FHM spring activated – hydraulically released</b>			<b>E 09.779e</b>	
Issue: 25.06.2021	Version: 2	Drawn: BAHS	Checked: EISF	Pages: 25	Page: 25

## 6 Spare parts

Monitoring switches (Opening/wearing) Ref.: CONOUVREG-PIN-HW

- Set of pads:

2 pads 12712-08 Ref: JGS HS145 RINGSPANN-12712

- Hydraulic control parts comprising (Refer to assembly drawing):

- ▶ 1 Piston 12712-004
- ▶ 1 Piston rod 12712-003
- ▶ 1 Piston rod seal JOITIG-070-080 Z
- ▶ 1 Piston seal JOIPIS-160-144.5 E
- ▶ 1 Static piston seal JOISTA-74.6-070 U
- ▶ 1 Cylinder 12712-005

In case of order, please specify:

Type, Nr. of the caliper and item Nr. of the part.

There is a type plate on the brake with a 16-digit article number. The exact design of the brake is defined by this article number only.

## 7 Troubleshooting

NATURE	VERIFICATION	SOLUTION
Decrease in braking force	- Check the pad gap	- Proceed with pad gap adjustment chapter 5
	- Check the condition of the pads and the disc (wear or grease particles).	- Replace the pads and clean the disc.
	- Check the pressure is zero	- No more pressure
Abnormal overheating of the disc during start-up.	- Insufficient gap between the pads and the disc in released position.	- Re-adjust the brake pads Chapter 5
	- Check that pressure is at 230bar	- Re-adjust pressure at 230bar
The caliper releases and closes slowly	- Air may be in the circuit	- Bleed according to chapter 2